

711257	Bracket Assy. (Inc. item 1)	Kit No.	
711261	Bracket Bolt Pkg. (Inc. items 8, 9, 14)	Make	Ford
None	Pulley Bolt Pkg.	Engine	6.8L
None	Idler Bolt Pkg.	Fuel	Gas
None	Fan Spacer Bolt Pkg.	Year	1999-2004
.....	Equipment	With A/C
.....	Revised	G 9-9-14

ITEM	PART #	DESCRIPTION
1.	711257	Pump mount bracket
2.	740297	Tensioner
3.	740302	Flat idler
4.	740143	Serpentine idler
5.	---	---
6.	*	Pump
7.	740148	Clutch
8.	110215	M10 x 120 x 1.5 Bolt
9.	110422	5/16-18 x 3/4 Bolt
10.	110718	M10 x 25 x 1.5 Bolt
11.	110213	M10 Torx head bolt
12.	110002	1/2-13 x 3 1/2 Bolt
13.	110425	3/8-16 x 1 1/4 Bolt
14.	110676	3/8 Flat washer
15.	740436	Crankshaft spider kit
16.	740332	Crankshaft pulley
17.	740299	Belt/Micro-V K080680

* See master list for pump part no.

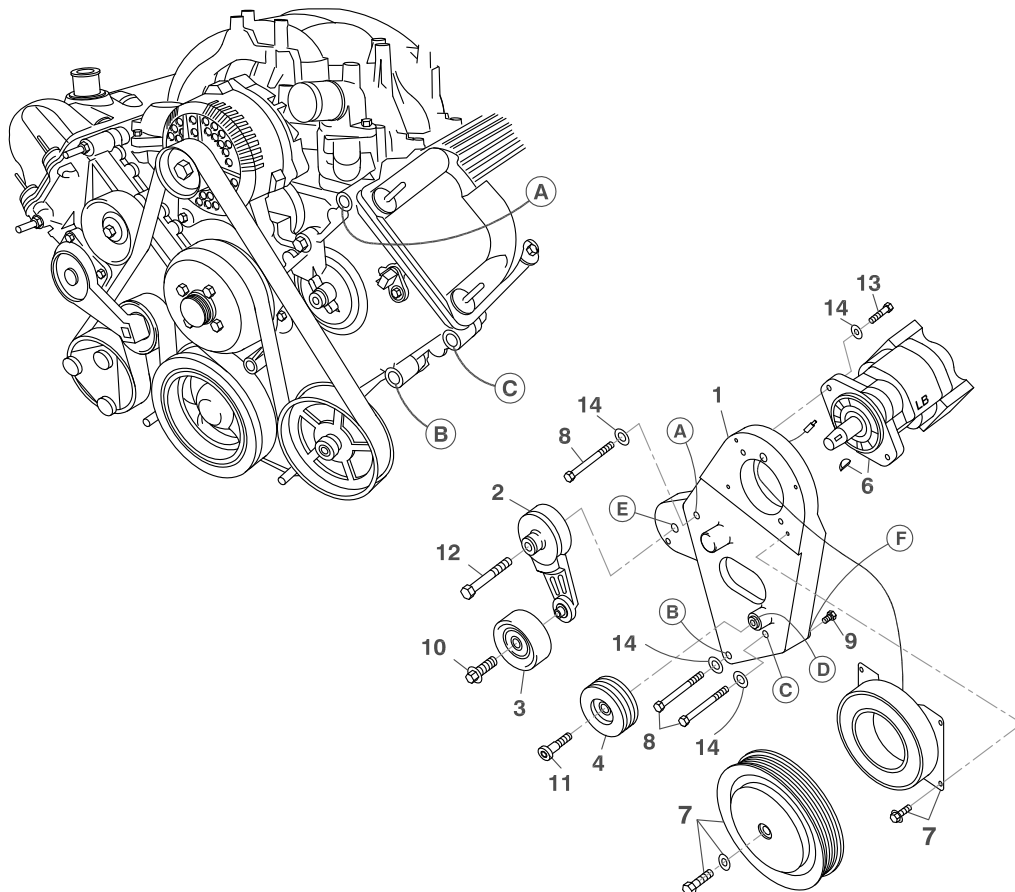

(A), (B), (C)... Denotes bolt holes in engine to locate corresponding holes in Pump Brkt.

FIG. 2

BELT DIAGRAM

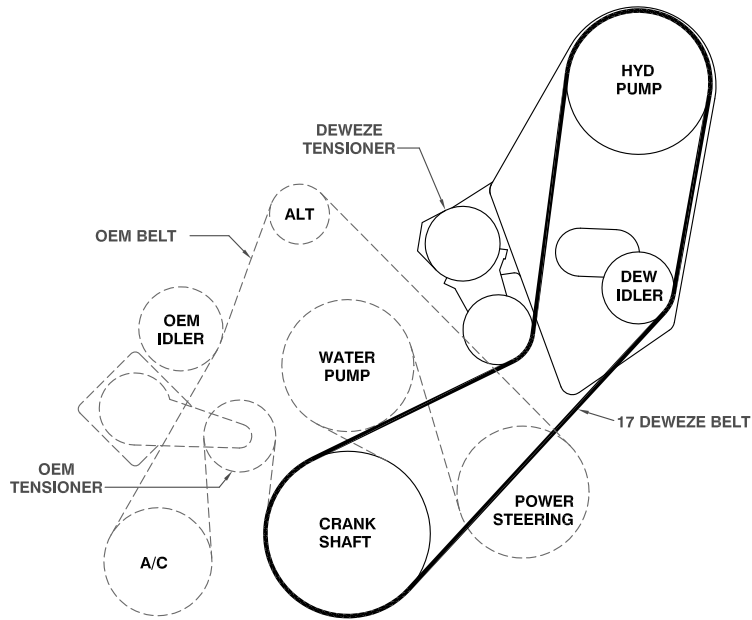
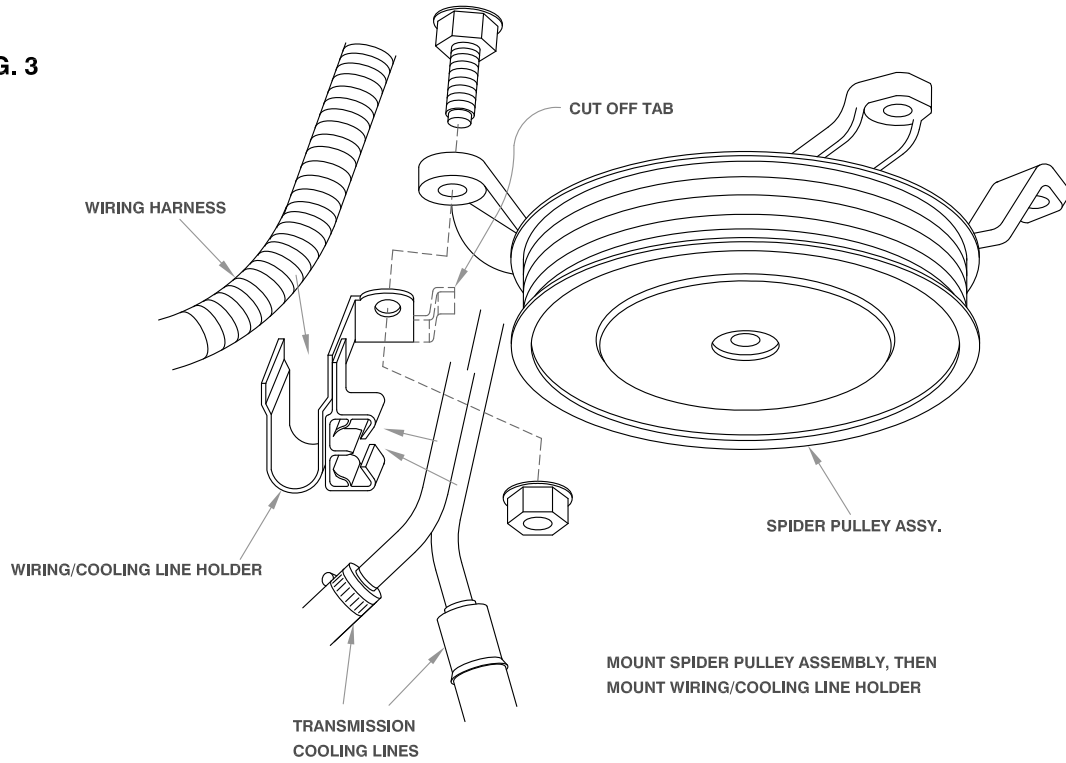

FIG. 3



DEWEZE

Clutch Pump Kit
#700350
Ford 6.8L
w/ and w/o A/C
'A' mount
1999-2004

INSTALLATION INSTRUCTIONS

1. Disconnect the battery.
2. Drain the radiator.
3. Remove the air cleaner assembly.
4. Remove the upper radiator hose. Cut 1.00" off the thermostat end. Make note, as to which end is which, as it will be turned around when it is installed later.
5. Remove the OEM belt.
6. Remove the fan shroud and fan. Remove the water pump pulley and water pump. Install the new water pump with extended hub that is furnished with the kit. Reinstall the original water pump pulley. Torque all bolts to specs in Ford installation sheets.
7. If your truck is model year 2000 or newer, remove the OEM crankshaft damper and replace with the new crankshaft damper supplied in the kit. Starting with model year 2002, the OEM engine belt drive is a 6-groove system. The crankshaft damper supplied in the kit has 8 grooves. The 8-groove damper can be used as a replacement. Please refer to the three pages from the Ford shop manual provided with these instructions for correct tools, installation, and torque procedure.
8. Reinstall the OEM belt placing it on the rear six grooves of the crankshaft damper leaving the front two grooves open.
9. Bolt the adapter hub to the center of the crankshaft pulley. Remove the wiring harness/transmission cooling line holder and cut off the tab as shown in Fig. 3. Install the spider pulley assembly by threading the pulley into the adapter and placing the legs over the stud bolts. Then place the cooling line holder back over the stud bolt it was taken from. Attach spider with two nuts and one bolt as shown. Torque the center adapter and the nuts and bolt to specs shown. Please refer to the four pages of spider mounting instructions provided.
10. Remove OEM bolts from engine at locations A, B, and C. Lay the wiring off to the side.
11. Bolt the pump (6) to the rear of the mounting bracket (1) using two 3/8 x 1 1/4 bolts (13) and two 3/8 flat washers (14). Attach clutch coil (7) to the front of the bracket using four flange bolts supplied with the clutch. Insert the coil wire through the 1/2" hole right above the coil to keep it from contacting the clutch pulley.
12. Attach the flat idler pulley (3) to the tensioner arm (2) with the 7/16 x 1 1/8 flange bolt (10). Mount the tensioner assembly on the pump bracket at location E with one 1/2 x 3 1/2 bolt (12), inserting the bolt head on the back of the tensioner into the small hole on the tensioner mounting pad.
13. Attach the serpentine idler pulley (4) onto the boss at location D with the M10 Torx head shoulder bolt (11).

14. Mount the pump bracket onto the engine at locations A, B, and C with the three M10 x 120 bolts (8) with 3/8 flat washers (14). Torque these bolts to 30-41 ft/lbs.
15. Bolt the wiring harness holder to the back of the pump bracket at location F using a 5/16 x 3/4 bolt (9).
16. Mount the clutch pulley (7) onto the pump shaft using the bolt and washer supplied with the clutch.
17. Install the pump drive belt (17) making sure pulleys are aligned and belt runs true.
18. Installation of the spider pulley will result in interference with the fan. The new water pump has an extended hub to move the fan forward for clearance between it and the pulley. The distance the fan is placed into the fan shroud is critical for maximizing cooling performance. The water pump moves the fan forward 1 1/2". Therefore, it is necessary to trim 1 1/2" off the shroud to maintain the original distance. Then reinstall the shroud and fan. Torque the fan to the specs shown. Make sure there are no clearance problems with the fan and shroud.
19. Replace the upper radiator hose, turning the ends opposite from the way it was originally. This is to give enough clearance between the clutch and the hose.
20. Replace the coolant in the radiator.
21. Reconnect the battery.
22. Run the engine and check for alignment and clearance problems.