

**Ford 6.2L: G, 2011+, AA Pump, Rear Port**

**BOLT PACKAGES:**

BRACKET	716053 (Inc. item 11-22)
IDLER PULLEY	None
CRANK PULLEY	None
TENSIONER	None
FAN SPACER	None

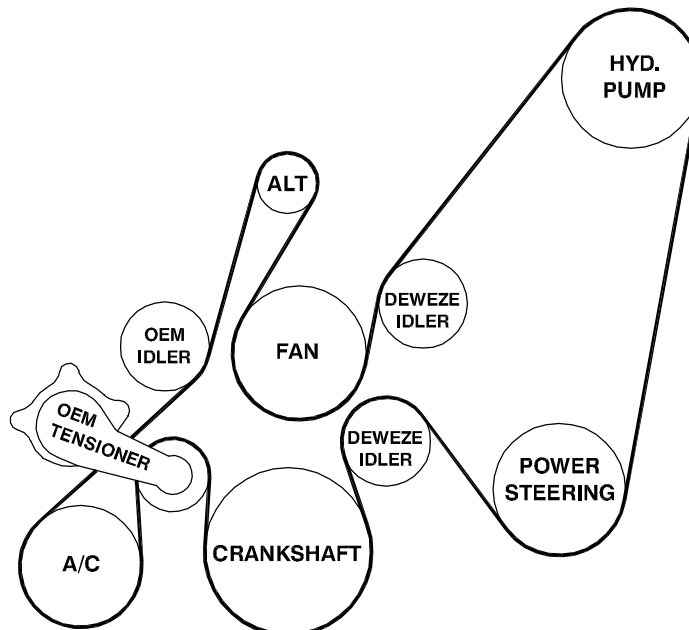
6-2-10 : ISSUE DATE : B : 2-14-11 REVISION DATE

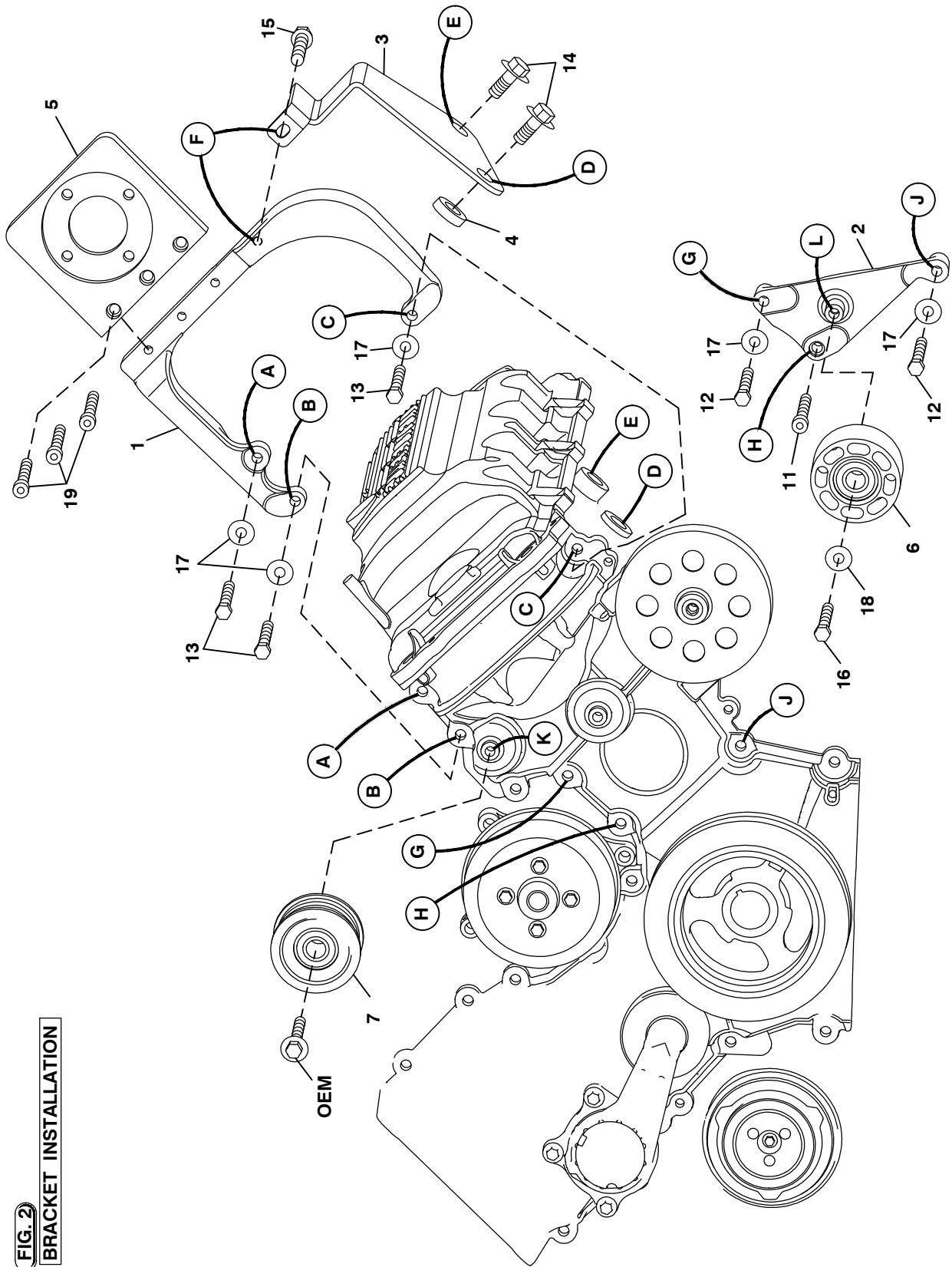
**Item | Quan. | Part No. | Description**

1.	1	716047	PUMP MOUNT BRACKET	23.	1	702111	AIR TUBE
2.	1	716048	IDLER BRACKET	24.	1	702112	REDUCER, AIR INTAKE
3.	1	716049	BRACE, PUMP MOUNT	25.	1	702113	ELBOW, AIRBOX
4.	1	716050	BUSHING, BRACE	26.	3	702114	CLAMP, 3.5"
5.	1	711291	PUMP PLATE	27.	1	702115	CLAMP, 4"
6.	1	740151	IDLER, FLAT	28.	1	120088	HOSE SPLICE
7.	1	740427	IDLER, 6-GROOVE	29.	1	716052	HOSE, 1.5" ID X 2.25" LONG
8.	1	110662	WASHER, 1/2 FLAT	30.	2	511002	CLAMP, HOSE #24 1.5"
9.	1	*	PUMP	31.	5	100578	CABLE TIE, 14"
10.	1	740162	CLUTCH, 6 GROOVE	32.	1	740430	BELT, 6 GROOVE, 126"
11.	1	110775	BOLT, M8 X 1.25 X 60				
12.	2	110569	BOLT, M8 X 1.25 X 65 LOWHEAD SOCKET				
13.	3	110558	BOLT, M8 X 1.25 X 50 HEX HEAD				
14.	2	110933	BOLT, M16 X 2.0 X 35 FLANGE 10.9				
15.	1	110437	BOLT, 3/8-16 X 0.75 WIZ FLNG				
16.	1	110435	BOLT, 3/8-16 X 1.5 HEX HEAD				
17.	5	110703	WASHER, M8 FLAT				
18.	1	110676	WASHER, 3/8 FLAT				
19.	3	110465	BOLT, 3/8-16 X 1.25 SOCKET HEAD				
20.	--	-----	-----				
21.	2	110465	BOLT, 3/8-16 X 1.25 SOCKET HEAD				
22.	2	110271	WASHER, 3/8 LOCK, .55 OD X .13 THICK				

**FIG. 1**

**BELT DIAGRAM**

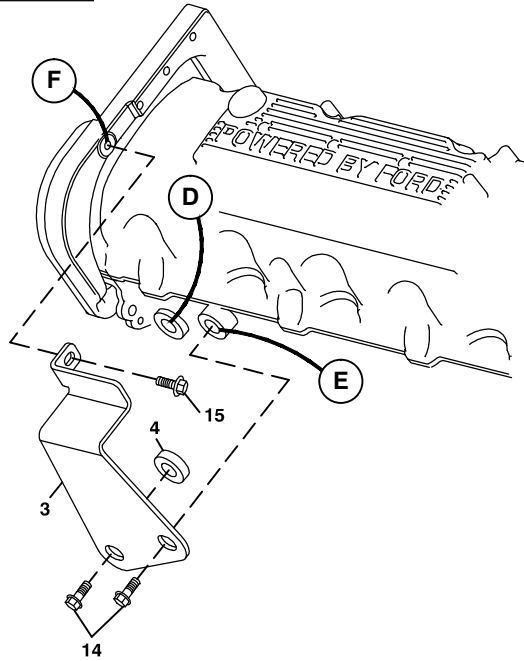




**FIG. 2**  
**BRACKET INSTALLATION**

**FIG. 3**

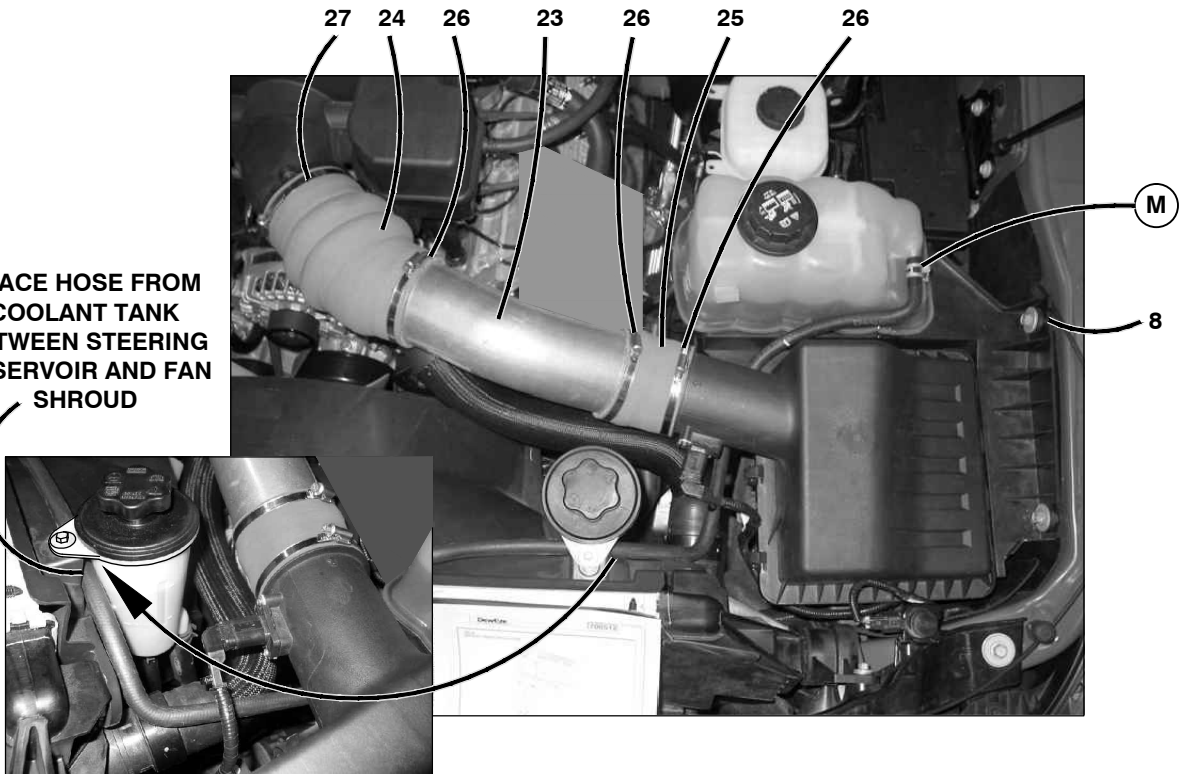
**BRACKET BRACE INSTALLATION**



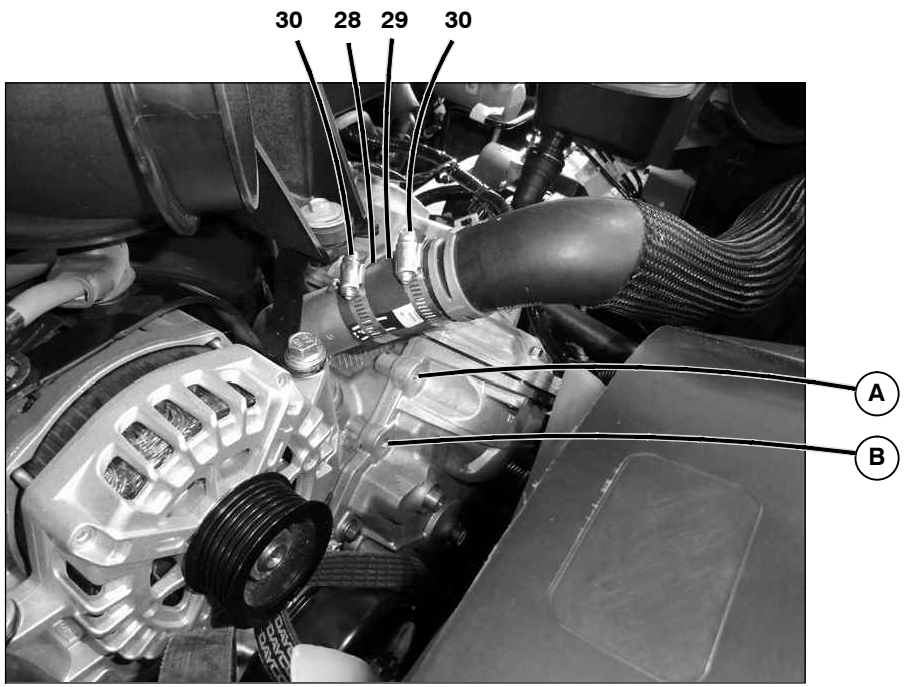
**FIG. 4**

**AIR TUBE REPLACEMENT**

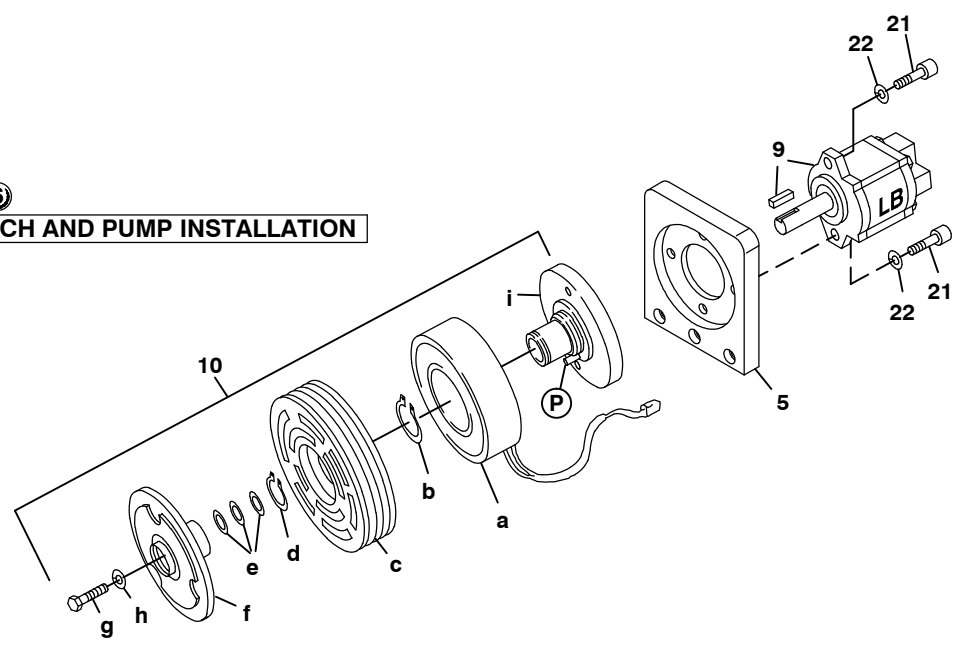
PLACE HOSE FROM COOLANT TANK BETWEEN STEERING RESERVOIR AND FAN SHROUD



**FIG. 5**  
**BRACKET LOCATION**  
**RADIATOR HOSE SPLICE**



**FIG. 6**  
**CLUTCH AND PUMP INSTALLATION**



# DewEZE Clutch Pump Kit 700513

Ford 6.2L Gas, AA Pump, Rear Port, 2011 +

## INSTALLATION INSTRUCTIONS

1. The installation of this kit requires trained decision-making concerning clearances, tying components together, rerouting, or relocating OEM components, etc. It is impossible to describe all of the clearance and vibration points, etc. in the installation instructions. Therefore, the technician must exercise professional judgment to achieve the best quality installation.
2. Disconnect the battery.
3. Remove the air tube connecting the air filter box to the intake box on top of the engine. Drain just enough of the engine coolant to remove the upper radiator hose from the engine water neck. Insert the hose splice (28) into the OEM radiator hose, push the short piece of radiator hose (29) onto the splice and onto engine with two 1.5" hose clamps (30). Unclamp the hose from the top front of the coolant tank (Location M), thread it between the power steering reservoir and the fan shroud and connect it back to the coolant tank. Replace coolant.
4. The supply hose for the power steering pump must be rotated to clear the new belt routing. Hold the spring clamp with locking pliers, and rotate the hose as far towards the driver side fender as possible. Using a cable tie (31), secure the steering hose to the radiator hose running between the coolant tank and the radiator.
5. Remove the rear bolt from the airbox attached to the fender, place the 1/2" heavy washer (8) between the airbox and the fender to angle the outlet tube forward. Reinstall the OEM bolt.
6. Remove the three bolts on the lower portion of engine at Locations G, H, and J. Install the idler bracket (2) with two M8 x 65 hex head bolts (12) and two M8 flat washers (17) at Locations G and J. Insert the M8 x 60 low head socket head bolt (11) at Location H. Install the flat idler (6) with 3/8 x 1 1/2 bolt (16) and 3/8 flat washer (18) at Location L.
7. Install the pump bracket brace (3) to the two large threaded holes on the side of the cylinder head at Locations D and E, placing the bushing (4) between the front hole and the bracket using M16 x 35 flange bolts (14). Do not completely tighten.
8. Remove the OEM flat idler at Location K. Remove the three bolts at locations A, B, and C. Install the pump bracket (1) with three M8 x 50 hex bolts (13) and three M8 flat washers (17). Fasten brace to pump bracket with 3/8 x 3/4 flange head bolt (15) through brace into back of pump bracket. Tighten all the bolts on the brace. Install the 6-groove idler (7) at Location K with the OEM bolt.
9. Hold pump (9) onto back of pump plate (5) and clutch hub (10i) onto front of bracket, making sure anti-rotation pin (P) on front of hub is on top. Place two 3/8 x 1 1/4 socket head bolts (21) and 3/8 high collar lock washers (22) through pump, through mounting plate and thread into hub. Torque to 20 lb-ft.
10. Slide coil (10a) over hub, aligning hole in the back plate of coil with the anti-rotation pin (P) in the hub. The wires from the coil should be on the same side as the pin (P). Install large snap ring (10b) to hold coil in place.

**NOTE: THE BEVEL ON BOTH SNAP RINGS MUST FACE AWAY FROM THE**

**PUMP. REFER TO INSTRUCTION SHEET FOR THE CLUTCH FOR CORRECT INSTALLATION OF SNAP RINGS.**

11. Slide clutch pulley (10c) onto hub. Install small snap ring (10d) to hold pulley in place.

12. Place the key onto the pump shaft. Slide the hub/armature (10f) onto the pump shaft aligning the keyways.

**NOTE: SET THE AIR GAP BETWEEN THE HUB/ARMATURE AND THE PULLEY USING SHIMS (10e) ACCORDING TO INSTRUCTION SHEET FOR CLUTCH.**

13. Thread bolt (10g) and lock washer (10h) into pump shaft. Torque to value in clutch instruction sheet.

14. Install belt (32) according to diagram.

15. Place elbow (25) onto airbox with 3.5" clamp (26). Insert DewEze air tube (23) into elbow using a 3.5" clamp (26). Place 3.5" end of reducer onto air tube using 3.5" clamp (26), also pushing 4" end onto air intake using the 4" clamp (27). Make sure there is clearance between the air tube and the clutch. Adjust the air tube and elbow by twisting them if needed.

16. Reconnect the battery.

17. Run the engine and check for any clearance or alignment problems. Adjust as needed.