

Bracket Assy.	None	
Bolt Packages:		
Bracket	711419	(Inc. items 6, 10, 12, 13, 19, 21-24, 26, 30, 31)
Pulley	711420	(Inc. items 20, 28)
Fan spacer	711421	(Inc. items 18, 19)
Tensioner	711422	(Inc. items 11, 17)

Make	Isuzu	
Engine	4.751L	
Fuel	Diesel	
Year	2002-2007	
Equipment	Turbo, A/C	
Revised	B	12-2-08

Item	Part No.	Description
1.	711416	Engine mount bracket
2.	711417	Pump plate
3.	740358	Crank pulley
4.	700254	Fan spacer
5.	711414	Shroud extender bracket
6.	711415	Shroud extender spacer
7.	*	Pump / Side port
8.	740144	Clutch
9.	OEM	Fan mount plate
10.	110569	M8 x 65 x 1.25 Bolt
11.	110217	M10 x 70 x 1.5 Bolt
12.	110535	7/16-14 x 1 1/2 Bolt
13.	110426	5/16-18 x 1/2 Flange bolt
14.	OEM	Alternator pivot bolt
15.	110425	3/8-16 x 1 1/4 Bolt
16.	743002	Tensioner
17.	110676	3/8 Flat washer
18.	110559	M8 x 40 x 1.25 Bolt
19.	110674	5/16 Lock washer
20.	110314	M16 x 80 x 1.5 Bolt
21.	110671	7/16 Lock washer
22.	110689	M10 Lock washer
23.	110665	5/16 Flat washer
24.	110558	M8 x 50 x 1.25 Bolt
25.	OEM	Bolt
26.	110643	M8 x 1.25 Nut
27.	OEM	Nut
28.	110669	5/8 Flat washer
29.	742002	Belt/Micro-V K060425
30.	110859	M10 x 80 x 1.5 Bolt
31.	110101	M10 x 1.5 Nut

FIG. 1
MOVE FAN
SHROUD FORWARD

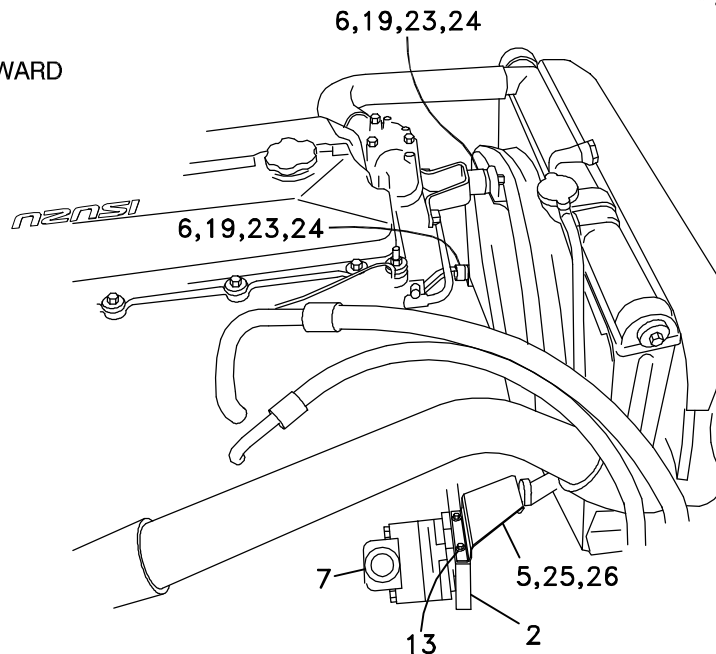

* See master list for pump part number.

FIG. 2
BELT DIAGRAM

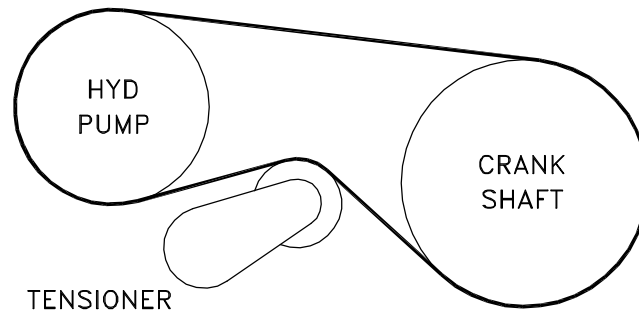

(A),(B),(C)... Denotes bolt holes in engine to locate corresponding holes in Pump Brkt.

FIG. 3

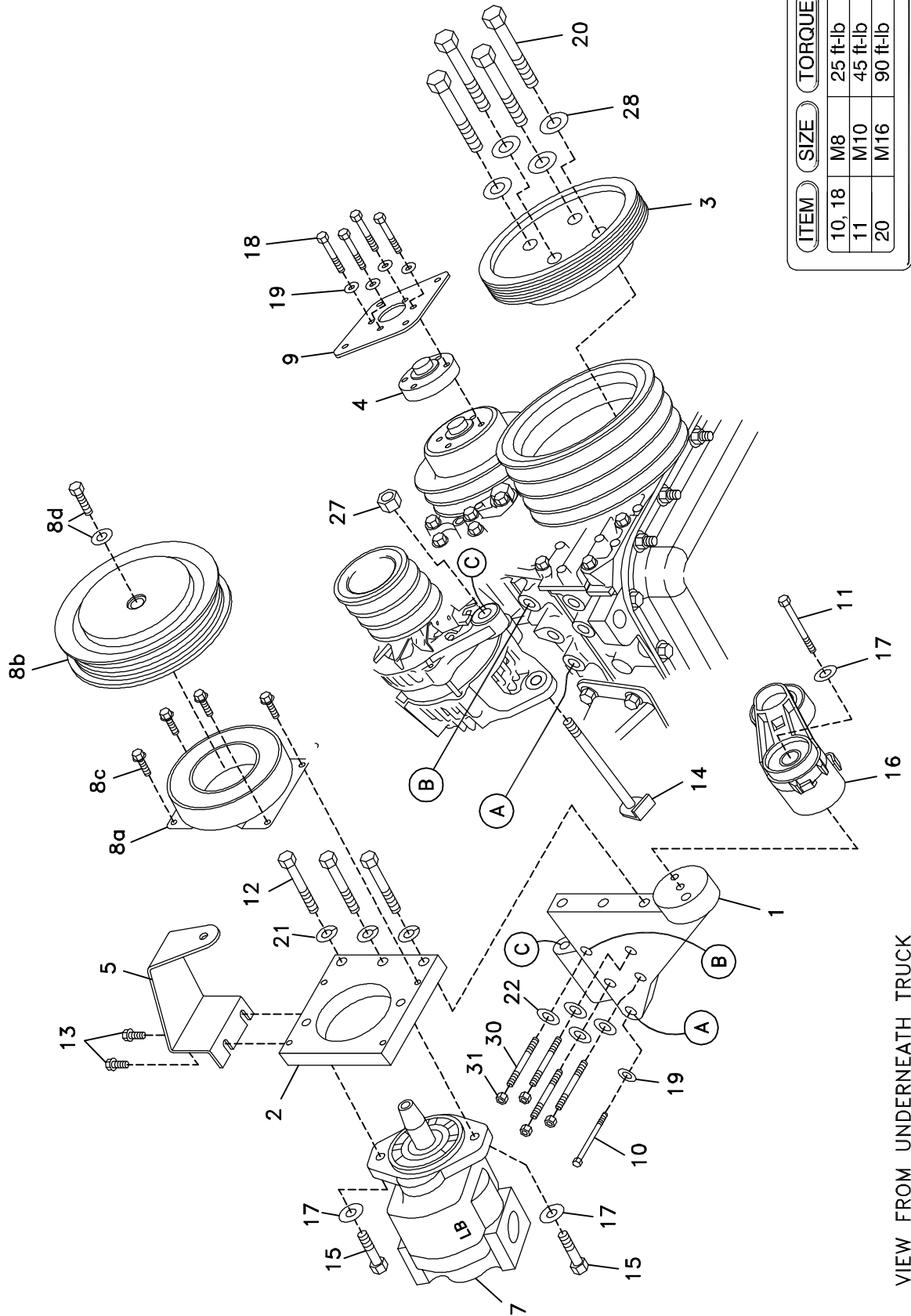

DewEze

Clutch Pump Kit

Clutch Pump Kit
700394
ISUZU
4.75L
'A' mount
2002-07

INSTALLATION INSTRUCTIONS

1. The front of the truck will need to be jacked up and set on blocks, as the installation will be underneath the truck.
2. Disconnect the battery.
3. Remove the bolts supporting the fan shroud at three locations. Save one bolt to be used on reinstallation.
4. Unbolt the fan from the square mounting plate. Lay the fan forward into the shroud. Save the nuts to use again.
5. Remove the square plate (9) from the water pump. Place the fan spacer (4) on the water pump. Place the OEM square plate on the fan spacer. Fasten the plate and fan spacer with four M8 x 40 bolts (18) and four 5/16 lock washers (19). Torque to 25 ft-lb.
6. Remove the inspection cover on the bottom of the bell housing to hold the engine from turning when the pulley bolts are removed and tightened back up. Remove the OEM crank pulley bolts. Install the crank pulley (3) with four M16 x 80 bolts (20) and four M16 flat washers (28). Torque to 90 ft-lb.
7. Loosen the alternator belt. Remove the pivot bolt and nut from the bottom of the alternator. Save these, as they will be used over again. Slide the bolt out of the alternator. Remove the fan shroud bracket and the alternator mount from the engine. These will not be used over.
8. Place Loctite® on one end of each of the four stud bolts (30) and thread into the engine at Location B. Slide the engine bracket (1) over the stud bolts and between the alternator mounting lugs at location C and attach with the OEM alternator bolt (14) and OEM nut (27). Fasten the bracket down with four M10 nuts (31) on the stud bolts. Torque these to 45 ft-lb. Insert the M8 x 65 bolt (10) with a 5/16 lock washer (19) into the bracket at location A. Torque this bolt to 25 ft-lb.
9. Tighten the alternator belts. Tighten any bolts that have been loosened.
10. Attach the pump (7) to the pump plate (2) with two 3/8 x 1 1/4 bolts (15) and two 3/8 flat washers (17). The suction port is positioned on top. Install the supplied fittings onto the pump. Don't tighten them yet. Hold the pump and plate up on the engine bracket to determine how the fittings should be rotated to get the hoses to them. Take the pump back down and tighten the fittings.
11. Insert a 7/16 x 1 1/2 bolt (12) with a 7/16 lock washer (21) into the center mounting hole on the pump plate. Attach the clutch coil (8a) using four 1/4 x 1/2 flange bolts (8c) supplied with clutch. Now mount the pump plate back onto the engine bracket with the other two 7/16 x 1 1/2 bolts and two 7/16 lock washers. Attach the clutch pulley (8b) with the 5/16 x 1 1/2 bolt (8d) and heavy flat washer.
12. Install the tensioner (16) onto the engine bracket with the M10 x 70 bolt (11) and 3/8 flat washer (17). Torque to 45 ft-lb.
13. Place the belt (29) on the clutch first then stroke the tensioner downward and slip the belt over the crank pulley.
14. Attach the fan back onto the square mounting plate (9) using the OEM nuts.
15. Mount the fan shroud extension bracket (5) onto the pump plate with two 5/16 x 1/2 flange bolts (13). Attach the bracket to the fan shroud using the OEM bolt (25) and the M8 nut (26). Do not tighten any of these bolts until all fan shroud bolts are in place. Attach the fan shroud at the top and driver's side using the round spacer (6) with an M8 x 50 bolt (24), a 5/16 lock washer (19), and a 5/16 flat washer (23) at each place. Tighten all the bolts.
16. Run the engine and check for any clearance or alignment problems. Adjust as needed.