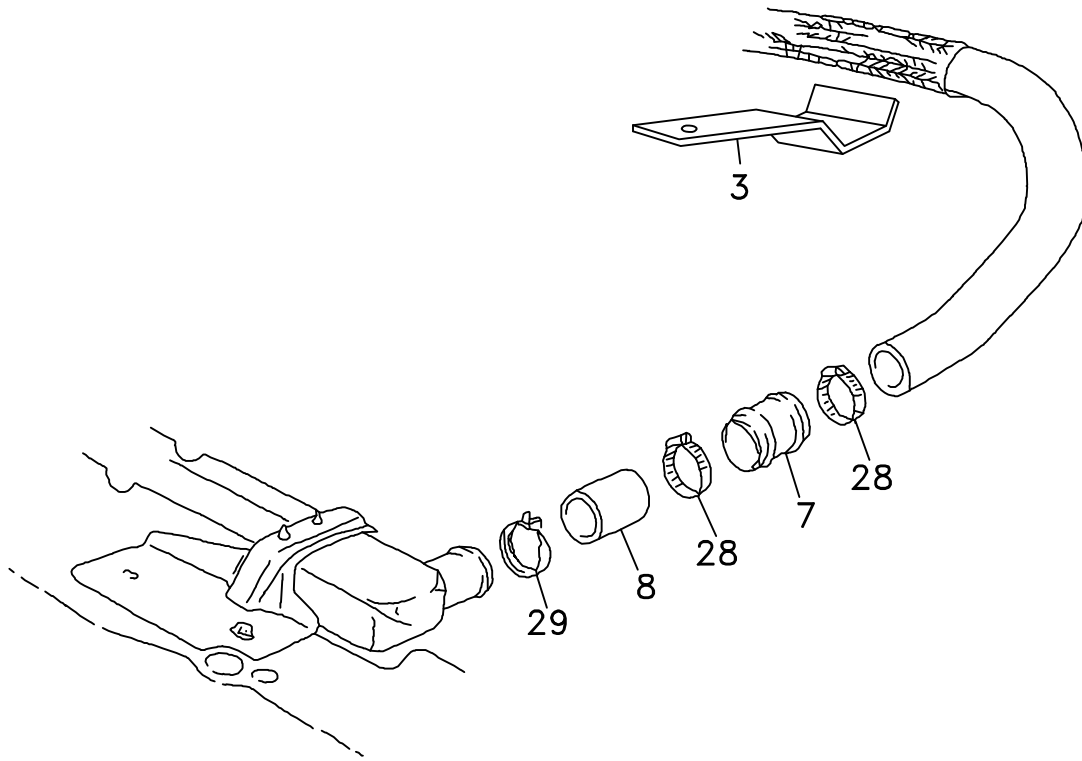

FIG. 2



DewEze

Clutch Pump Kit
#700340
Chevy 6.5L
With A/C
1999

INSTALLATION INSTRUCTIONS

NOTE: Suction hose to pump must be a wire braid hose; minimum 1" I.D. for 7 and 9 gpm pumps; 1 1/4" I.D. for 12 and 17 gpm pumps. Installation with smaller suction hoses will void the pump warranty.

1. Disconnect battery.
2. Remove top half of radiator shroud and the fan.
3. Unbolt OEM bolt (27) on air conditioner at location (G). Remove OEM hose holder from locations A and B. Keep these bolts to mount the DewEze bracket.
4. Remove radiator hose from radiator. Place 3" section of radiator hose (8) on radiator, using OEM clamp (29). Insert brass hose splice (7) into 3" hose and place OEM hose over splice using hose clamps (28).
5. Place DewEze hose holder (3) on air conditioner at location (G) using OEM bolt (27).
6. Place serpentine idler (31) with 5/8 x 3 1/2 bolt (16), bushing (6) and two 5/8 flat washers (19) onto hole (E) and secure with 5/8 flat washer (19) and 5/8 lock nut (20) on back of bracket.
7. Place bracket (1) into place using OEM bolts (12) at locations (A and B) and 10mm x 30mm bolts (11) at locations (C and D).
8. Place the three shims (17) onto boss on end of tensioner arm (35). Set flat idler (32) over boss. Insert M10 x 50 bolt (33) through idler bushing (18), through the idler and thread into the tensioner arm. Mount tensioner onto pump mounting bracket (1) at location F, placing locating hole on back of tensioner over roll pin in bracket. Thread 1/2 x 3 1/2 bolt (34) through center of tensioner into bracket, tighten, and secure on back with 1/2 wiz flange nut (36).
9. Bolt pump (9) onto back side of pump plate (2) using 3/8 x 1 1/4 bolts (14) and 3/8 lock washers (15).
10. Bolt pump and plate onto bracket using three 3/8 x 1 socket head screws (13).
11. Place clutch coil on pump plate using four wiz flange bolts provided with clutch. Place clutch onto pump shaft aligning keyway and securing with bolt and flat washer provided with clutch.
12. Install the DewEze crankshaft pulley (4) using four 10mm x 120mm bolts (21).
NOTE: The flange is short on the OEM pulley that centers the DewEze pulley. Make sure the flange and the machined DewEze pulley are lined up before tightening bolts.
13. Install the DewEze serpentine belt (30).
14. With belts tightened, run the engine and check for any installation or alignment problems. Adjust as needed.
15. Place fan and shroud into position.
16. Start and run the engine again, checking for any problems.