

DEWEZE

710042	Bracket Assy. (Inc. items 1, 2, 29, 34)	Clutch Pump Kit	700046
710801	Brkt Bolt Pkg. (Inc. items 5-11,22-26,31-33,36)	Make	Chevy
710431	Pulley Bolt Pkg. (Inc. items 18-23)	Engine Size	350
710354	Idler Bolt Pkg. (Inc. items 13-17)	Fuel	Gas
None	Fan Spacer Bolt Pkg.	Year	1990-94.5
		Options	2 Batteries
		Revised	D 2-13-04

ITEM	PART NO.	DESCRIPTION
1.	710422	Bracket
2.	710411	Pivot Plate
3.	740019	Crankshaft pulley
4.	740040	Idler pulley
5.	710421	Spacer, .985" long
6.	110072	10mm X 150mm X 1.5 Bolt
7.	110640	10mm nut
8.	110512	1/2 X 5 NC Bolt
9.	110666	1/2 Lock washer
10.	110610	1/2 Nut
11.	110437	3/8 X 3/4 NC Wiz Bolt
12.	OEM	Nut
13.	110513	5/8 X 2 1/2 NC Bolt
14.	110668	5/8 Machine bushing (10 ga.)
15.	110669	5/8 Machine bushing (14 ga.)
16.	110650	5/8 Flat washer
17.	110639	5/8 Lock nut
18.	110551	7/16 X 5 1/4 NF Bolt
19.	110671	7/16 Lock washer
20.	110670	7/16 Flat washer
21.	110499	3/8 X 4 NF Bolt
22.	110672	3/8 Lock washer
23.	110676	3/8 Flat washer
24.	110425	3/8 X 1 1/4 NC Bolt
25.	130011	Adel clamp
26.	110609	1/4 NC Nut
27.	*	Pump
28.	740064	V-belt, Gates A68
29.	710581	Pump plate
30.	-----	-----
31.	110422	5/16 X 3/4 NC Bolt
32.	110674	5/16 Lock washer
33.	110608	5/16 Nut
34.	710582	Cannister bracket
35.	OEM	Bolt
36.	720124	Hose clamp
37.	711216	Footmount
38.	740037	Clutch, standard
	740038	Clutch, Heavy duty

* See Master List For Pump Part No.

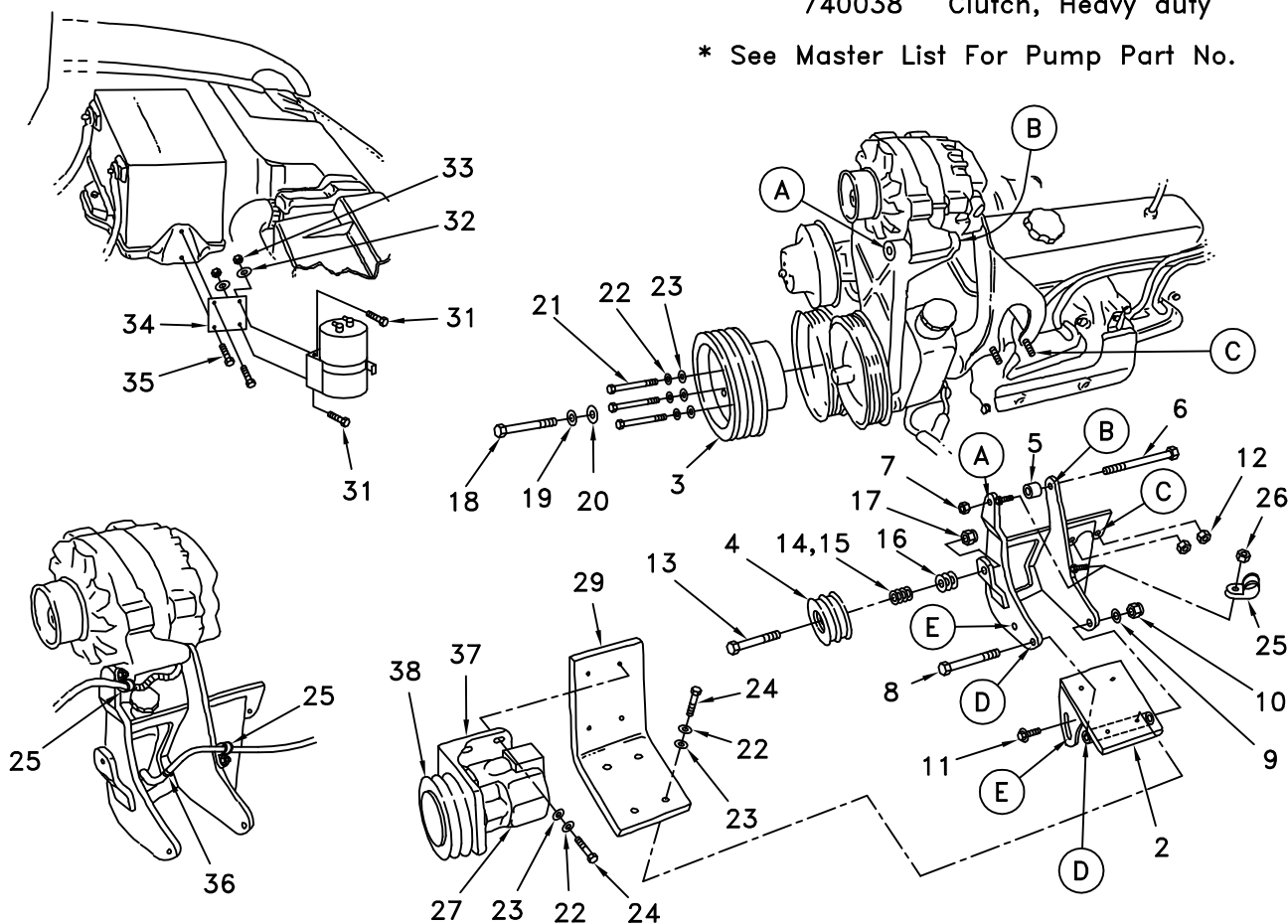

(A) Denotes bolt holes in engine to locate corresponding holes in Pump Brkt.

Chevy 350 (5.8L)
1990-93
(With two batteries)
Clutch Pump Kit #700046

INSTALLATION INSTRUCTIONS

NOTE: Suction hose to pump must be a wire braid hose; minimum 1" I.D. for 7 & 9 gpm pumps, 1 1/4" I.D. for 12 & 17 gpm pumps. Installations with smaller suction hoses will void the pump warranty.

1. Remove top half of fan shroud.
2. Remove fan.
3. Loosen and remove the OEM Serpentine belt.
4. Remove the four bolts from the OEM crankshaft pulley.
5. Install the DewEze crankshaft pulley (3) using three 3/8" X 4" NF Bolts (21) and one 7/16" X 5 1/4" NF Bolt (18), with a flat washer and lock washer on each bolt.
6. Install two of the OEM nuts back onto the water pump to hold the water pump in place.
7. Remove the two OEM nuts (12) at location C.
8. Remove the OEM alternator mounting bolt at Location A.
9. Remove the return hose coming out the side of the power steering pump.
10. Lower the DewEze bracket (1) into position according to drawing and install the power steering return hose through the large square hole in DewEze bracket using the hose clamp (36) to hold hose in position.
11. Position the bracket (1) onto the stud bolts at Location C.
12. Install 10mm X 150mm bolt (6) at Location A and B, with .985" spacer (5) between the bracket and alternator at location B.
13. Tighten Bolt (6) into the threads on the alternator bracket. Then install the 10mm nut (7) onto bolt (6) and tighten against the DewEze bracket at location A.
14. Install and tighten the two OEM nuts against the DewEze bracket at location C.
15. Place one Adel clamp (26) around Power Steering hose and over the lower bolt that is welded on the edge of the DewEze bracket. Place the other Adel clamp around alternator cable and over the upper bolt on the Deweze bracket. Fasten both clamps with a 1/4" nut (27).
16. Install the Pump Plate (29) onto the Pivot Plate (2) using four 3/8" X 1 1/4" Bolts (24), Flat Washers, Lock Washers, and Nuts.

17. Install Pivot Plate (2) at Location D using a 1/2" X 5" Bolt (8) and lock washer and nut. Install the 3/8" X 3/4" Wiflange Bolt (11) through adjusting slot at Location E into the main bracket (1). Tighten bolts.
18. Install and tighten the OEM belt.
19. Place the A68 Belts (28) on the DewEze crankshaft pulley and Clutch pulley (38) while installing the pump and clutch assembly onto the mounting Plate (2). Fasten the pump with four 3/8" X 1 1/4" Bolts (24), flat washers, and lock washers.
20. Align the clutch pulley with the crankshaft pulley, using a straight edge. Tighten the four pump mount bolts securely.
21. Install the idler pulley (4) using the 5/8" X 2 1/2" Bolt (13), and bushings or washers (14,15,16) as needed to align idler pulley with crankshaft and clutch pulleys.
22. Loosen Pump plate bolts (8 and 11). Pivot the plate to tighten belts, then securely tighten bolts.
23. Run engine, checking for clearance, alignment, and vibrations.
24. Install fan and shroud.
25. Retighten belts if necessary.