

# DEWEZE

710028	Bracket Assy. (Inc. items 1,2)	Clutch Pump Kit	700007
710457	Bracket Bolt Pkg. (Inc. items 3,6-9,20,23,24,30-35,37)	Make	Chevy
710430	Pulley Bolt Pkg. (Inc. items 19-24)	Engine Size	350
710355	Idler Bolt Pkg. (Inc. items 25-29)	Fuel	Gas
700181	Fan Spacer Bolt Pkg. (Inc. item 16-18)	Year	1985-87
		Options	Large Pilot
		Revised	B 4-28-95

ITEM	PART #	DESCRIPTION
1.	710880	Pump bracket
2.	710206	Bridge bracket
Ⓞ3.	710209	Spacer 2.625"
	710213	Spacer 2.420"
4.	-----	-----
5.	-----	-----
6.	710212	Spacer 4.430"
7.	710211	Spacer .765"
8.	710132	Spacer .400"
9.	710148	Spacer .200"
10.	740018	Pulley
11.	700170	Fan spacer
12.	740040	Idler pulley
13.	*	Pump
14.	740037	Clutch, standard
	740038	Clutch, heavy duty
15.	710353	Footmount
16.	710344	5/16 x 2 NC Stud
17.	110674	5/16 Lock washer
18.	110608	5/16 NC Nut
19.	110501	7/16 x 3 1/2 NF Bolt
20.	110671	7/16 Lock washer
21.	110670	7/16 Flat washer
22.	110497	3/8 x 2 1/2 NF Bolt
23.	110676	3/8 Flat washer
24.	110672	3/8 Lock washer
25.	110477	5/8 x 3 NC Bolt
26.	110668	5/8 Machine bushing (10 Ga.)
27.	110669	5/8 Machine bushing (14 Ga.)
28.	110650	5/8 Flat washer
29.	110639	5/8 NC Lock nut
30.	110541	3/8 x 6 1/4 NC Bolt
31.	110495	3/8 x 3 3/4 NC Bolt
32.	110577	12mm x 45mm Bolt
33.	110425	3/8 x 1 1/4 NC Bolt
34.	110612	3/8 NC Nut
35.	110545	7/16 x 2 1/2 NC Bolt
36.	740061	V-Belt A65
37.	110641	7/16 NC Nut

\* See Master List for Pump Part No.

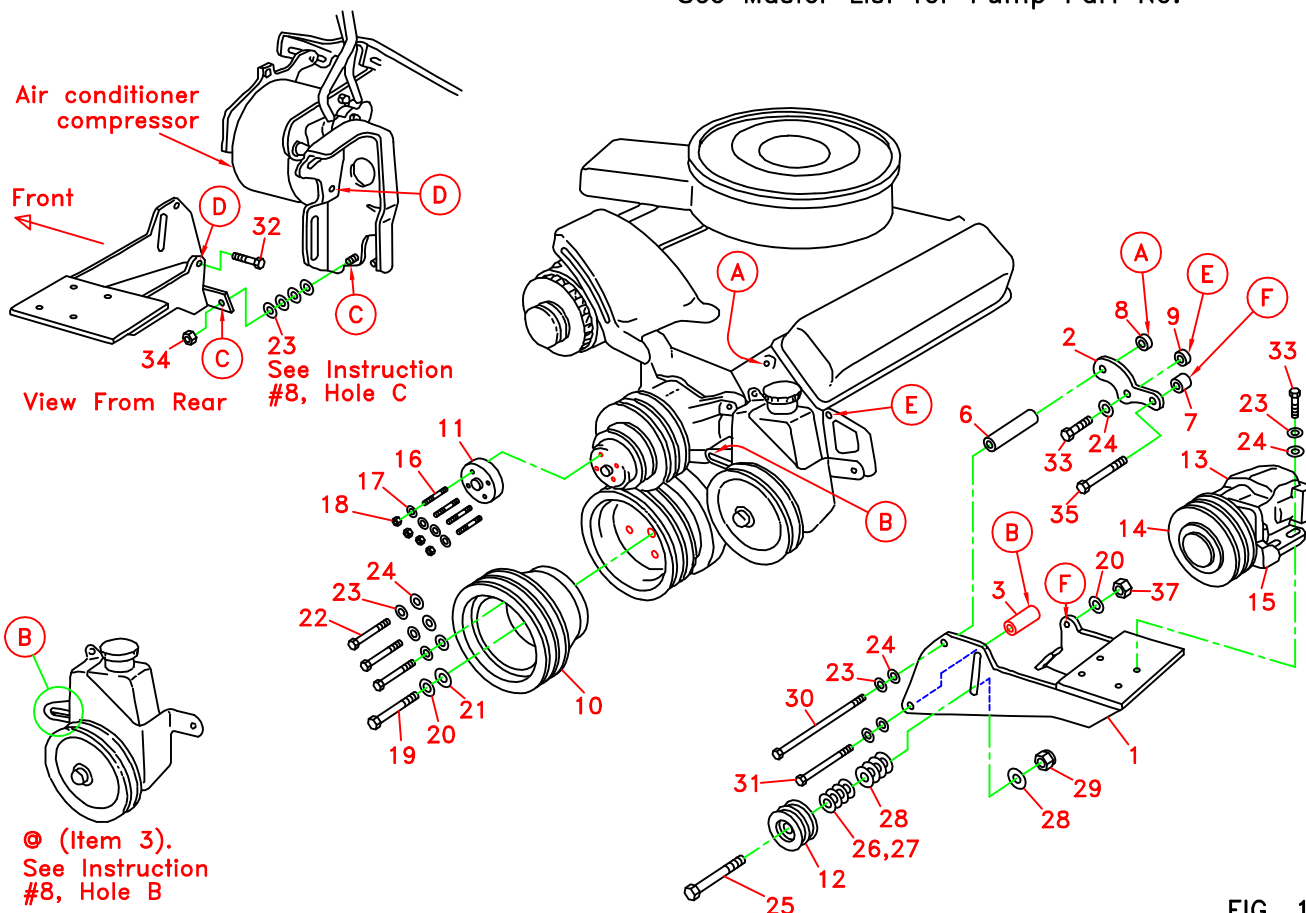
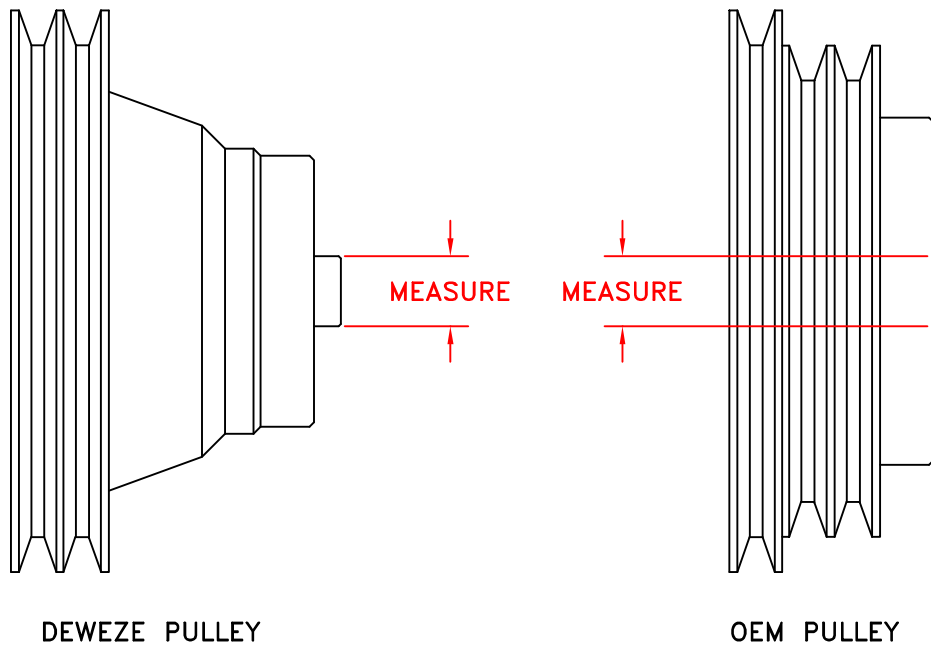

FIG. 1

Ⓐ Denotes bolt holes in engine to locate corresponding holes in Pump Brkt.

FIG. 2



Chevy 350  
1985-87 Without A/C  
Large Pilot C/S Pulley  
Clutch Pump Kit #700007

## INSTALLATION INSTRUCTIONS

**NOTE: Suction hose to pump must be a wire braid hose; minimum 1" I.D. for 7 & 9 gpm pumps; 1 ¼" I.D. for 12 & 17 gpm pumps. Installations with smaller suction hoses will void the pump warranty.**

1. Remove fan and shroud.
2. Loosen all OEM belts.
3. Remove the OEM crankshaft pulley bolts.
4. Install the DewEze crankshaft pulley (10) using three 3/8" X 2 ½" NF bolts (22) and one 7/16" X 3 ½" NF bolt (19) with lock and flat washers on each bolt.

**NOTE: This engine comes from the factory with either 1.112" or .980" diameter hole in the crankshaft pulley. Check to make sure you have the right pulley. Identify small or large pilot by the 8<sup>th</sup> letter of the truck VIN: K = small pilot, M = large pilot. Or you can measure the hole in the OEM pulley to determine which you have (see Fig. 2). Do not install the DewEze pulley if it is not the same diameter.**

5. Remove the OEM stud bolts in water pump pulley.
6. Install four DewEze Stud bolts (16) and Fan Extension (11). Fasten temporarily with two nuts and lock washers.
7. Tighten all OEM bolts.
8. Install pump mounting Bracket (1) as follows:

Hole A: Use 3/8 x 6 ¼ bolt (30) with lock washer. Place the 4.430" spacer (6) between pump bracket (1) and bridge bracket (2). Place .375" spacer (8) between bracket (2) and engine.

Hole B: Use 3/8 x 3 ¾ bolt (31) with lock washer. If power steering pump has tab at hole B use 2.420" spacer (3). If there is no tab use the 2.625" spacer (3). Power steering pulley may rub on bolt and spacer at Hole B when belt is tightened. If so, replace the power steering belt with a belt ½ " longer (Gates #7400, not included).

Hole C: With stainless steel exhaust manifold use four 3/8 flat washers (23) between bracket and manifold. With cast iron manifold use two washers between bracket and manifold. Thread 3/8 nut (34) onto existing stud.

Hole D: Use 12mm x 45mm bolt (32).

Hole E: Use 3/8 x 1 ¼ bolt (33) with lock washer. Place .250" spacer (9) between bracket (2) and engine.

Hole F: Use 7/16 x 2 ½ bolt (35) with lock washer. Place .750" spacer between bridge bracket (2) and pump bracket (1).

9. Set Pump assembly on bracket with the two Belts (36) on pulleys. Install the four 3/8" x 1 ¼" bolts (33) and lock and flat washers in pump assembly. Tighten nuts finger tight only at this time.
10. Using a straight edge, align Clutch and Crankshaft pulleys. Tighten the four mounting bolts.

11. Install Idler Pulley (10) using 5/8" x 3" bolt (25) and lock nut (29). Use 5/8" machine bushings and flat washers (26, 27, 28) as needed to align Idler with belts.
12. Tighten belts and run engine, checking for vibration, clearance, alignment and other installation problems.
13. Remove the two nuts holding the fan spacer on. Replace fan using four nuts and lock washers. Reinstall fan shroud.
14. Run engine again, checking for proper clearance and alignment.