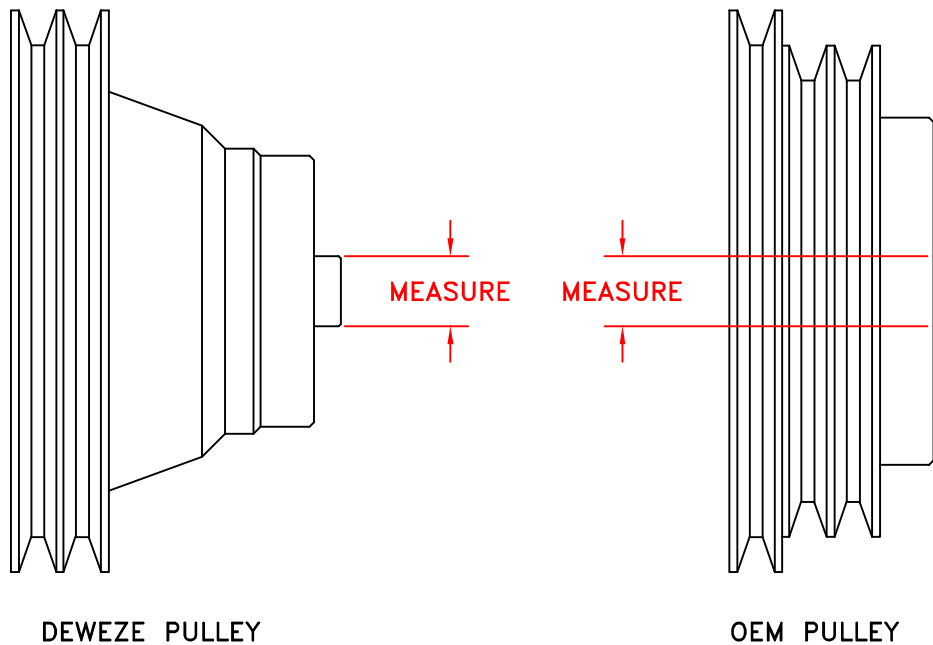

FIG. 2



Chevy 350
1985-87 Without A/C
Small Pilot C\S Pulley
Clutch Pump Kit #700006

INSTALLATION INSTRUCTIONS

NOTE: Suction hose to pump must be a wire braid hose; minimum 1" I.D. for 7 & 9 gpm pumps; 1-1/2" I.D. for 12 & 17 gpm pumps. Installations with smaller suction hoses will void the pump warranty.

1. Remove fan and shroud.
2. Loosen all OEM belts.
3. Remove the OEM crankshaft pulley bolts.
4. Install the DewEze crankshaft pulley (10) using three 3/8" X 2 1/2" NF bolts (22) and one 7/16" X 3 1/2" NF bolt (19) with lock and flat washers on each bolt.

NOTE: This engine comes from the Factory with either 1.112" or .980" diameter hole in the crankshaft pulley. Check to make sure you have the right pulley. Identify small or large pilot by the 8th letter of the truck VIN: K = small pilot, M = large pilot. Or you can measure the hole in the OEM pulley to determine which you have (see Fig. 2). Do not install the DewEze pulley if it is not the same diameter.

5. Remove the OEM stud bolts in water pump pulley.
6. Install four DewEze Stud bolts (16) and Fan Extension (11). Fasten temporarily with two nuts and lock washers.
7. Tighten all OEM belts.
8. Install pump mounting Bracket (1) as follows:

Hole A: Use 3/8 x 6 1/4 bolt (30) with lock washer. Place 4.430" spacer (6) between pump bracket (1) and bridge bracket (2). Place .375" spacer (8) between bracket (2) and engine.

Hole B: Use 3/8 x 3 3/4 bolt (31) with lock washer. If power steering pump has tab at hole B use 2.420" spacer (3). If there is no tab use 2.625" spacer (3). Power steering pulley may rub on bolt and spacer at Hole B when belt is tightened. If so, replace the power steering belt with a belt 1/2" longer (Gates #7400, not included).

Hole C: With stainless steel exhaust manifold use four 3/8 flat washers (23) between bracket and manifold. With cast iron manifold use two washers between bracket and manifold. Thread 3/8 nut (34) onto existing stud.

Hole D: Use 12mm x 45mm bolt (32).

Hole E: Use 3/8 x 1 1/4 bolt (33) with lock washer. Place .250" spacer (9) between bracket (2) and engine.

Hole F: Use 7/16 x 2 1/2 bolt (35) with lock washer. Place

.750" spacer between bridge bracket (2) and pump bracket (1).

9. Set Pump assembly on bracket with the two Belts (36) on pulleys. Install the four 3/8" x 1 1/4" bolts (33) and lock and flat washers in pump assembly. Tighten nuts finger tight only at this time.
10. Using a straight edge, align Clutch and Crankshaft pulleys. Tighten the four mounting bolts.
11. Install Idler Pulley (10) using 5/8" x 3" bolt (25) and lock nut (29). Use 5/8" machine bushings and flat washers (26,27,28) as needed to align Idler with belts.
12. Tighten belts and run engine, checking for vibration, clearance, alignment, and other installation problems.
13. Remove the two nuts holding the fan spacer on. Replace fan using four nuts and lock washers. Reinstall fan shroud.
14. Run engine again, checking for proper clearance and alignment.